

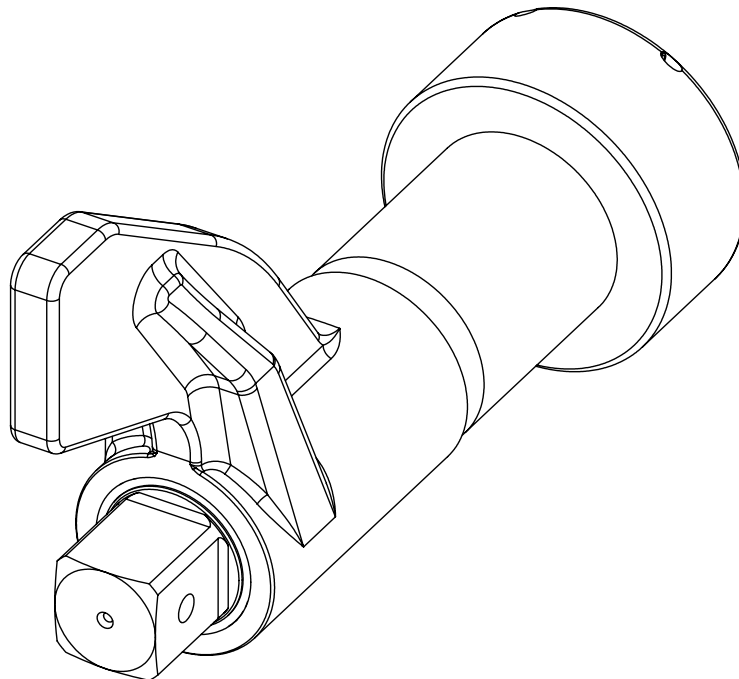

PNEUTORQUE[®] 72 SERIES, PTM & HANDTORQUE[™] NOSE EXTENSIONS

OPERATORS HANDBOOK (PART NO.34324) Issue 3
(ENGLISH)



CONTENTS

	<u>PAGE</u>
Part Numbers Covered By This Handbook	2
Introduction & Safety	3
Specification	4
Fitting Instructions	8
Operating Instructions	11
Maintenance	12

PART NUMBERS COVERED BY THIS HANDBOOK

This handbook covers the setup and use of Norbar nose extensions.

PART NUMBER	TO FIT	FITTING	DRIVE SQUARE SIZE	MAXIMUM TORQUE
16480.006 16480.009 16480.012	PT1/PT2 (3/4")	F/M	3/4"	1700 N·m
16484.006 16484.009 16484.012	PT5/HT5	F/M	1"	3400 N·m
16542.006 16542.009 16542.012	PT1/PT2/HT2 (1")	F/M	1"	1700 N·m
16694.006 16694.009 16694.012	PT5/HT5	M/M	1"	3400 N·m
16695.006 16695.009 16695.012	PT2/HT2 (HEAVY DUTY VERSIONS)	M/M	1"	1700 N·m
18349.006 18349.009 18349.012 18349.015 18349.018	PT500-2000	SPM/SPF	3/4" / 1"	2000 N·m
18594.006 18594.009 18594.012	PT-52	F/M	3/4"	800 N·m
18601.006 18601.009 18601.012	PTM-52	F/M	3/4"	800 N·m
18755.006 18755.009 18755.012	PTM-72	SPM/M	1"	2000 N·m
19007.006 19007.009 19007.012	PTM-72	SPM/M	1"	2000 N·m
19045.006 19045.009 19045.012	PTM-52	F/M	3/4"	800 N·m
19046.006 19046.009 19046.012	PTM-72	F/M	3/4"	2000 N·m
19047.006 19047.009 19047.012	PTM-72/92	F/M	1"	3500 N·m
19087.009 19087.012	PTM-72	F/M	3/4"	1000 N·m
19089.009 19089.012	PTM-72	F/M	1"	1000 N·m

Part number format:

PART NUMBER	EXTENSION DRIVE LENGTH
XXXXX.006	6"
XXXXX.009	9"
XXXXX.012	12"
XXXXX.015	15"
XXXXX.018	18"

Descriptions of fittings:

TYPE	DESCRIPTION
F/M	Female square to male square
M/M	Male square to male square
SPM/SPF	Male spline to female spline
SPM/M	Male spline to male square

INTRODUCTION

The nose extensions are designed for the use in situations where tool access is restricted.

SAFETY

IMPORTANT: DO NOT OPERATE THE TOOL BEFORE READING THESE INSTRUCTIONS. FAILURE TO DO SO MAY RESULT IN PERSONAL INJURY OR DAMAGE TO THE TOOL.

All Nose extensions are to be used only with Norbar compatible products.

This tool is intended for use with threaded fasteners.

Unexpected tool movement due to reaction forces or breakage of drive square or reaction bar may cause injuries.

Isolate the tool from all energy sources before changing or adjusting the drive square or socket.



There is a risk of crushing between the reaction bar and work piece.
Keep hands away from reaction bar.
Keep hands away from tool output.

Keep loose clothing, hair, etc. from being caught in any rotating part of the tool.

Unexpected direction of inserted tool movement can cause a hazardous situation.

Use only sockets and adaptors which are in good condition and are intended for use with power tools.

SPECIFICATION

Dimensions and weight of nose extensions.

PT1, PT2, PT5, HT2 & HT5

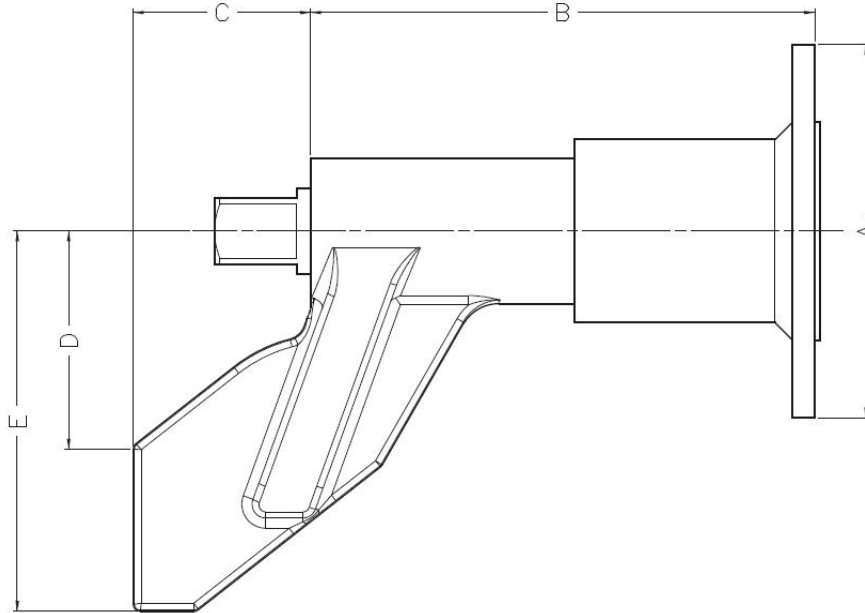

PART NUMBER	TO FIT	DIMENSIONS (mm)					WEIGHT (Kg)
		A	B	C	D	E	
16480.006	PT1/PT2 (3/4" SQ. DR. OUTPUT)	108	146	51	63	110	2.9
16480.009		108	224	51	63	110	3.7
16480.012		108	300	51	63	110	4.5
16484.006	PT5/HT5	119	146	72	81	124	5.1
16484.009		119	222	72	81	124	6.2
16484.012		119	300	72	81	124	7.4
16542.006	PT1/PT2/HT2 (1" SQ. DR OUTPUT)	108	146	72	81	124	5.1
16542.009		108	221	72	81	124	6.2
16542.012		108	297	72	81	124	7.4
16694.006	PT5/HT5	119	146	72	81	124	5.4
16694.009		119	209	72	81	124	6.8
16694.012		119	285	72	81	124	8.2
16695.006	PT2/H2 (HEAVY DUTY VERSION)	108	146	72	81	124	5.2
16695.009		108	221	72	81	124	6.6
16695.012		108	297	72	81	124	8.0

PT500 – 2000

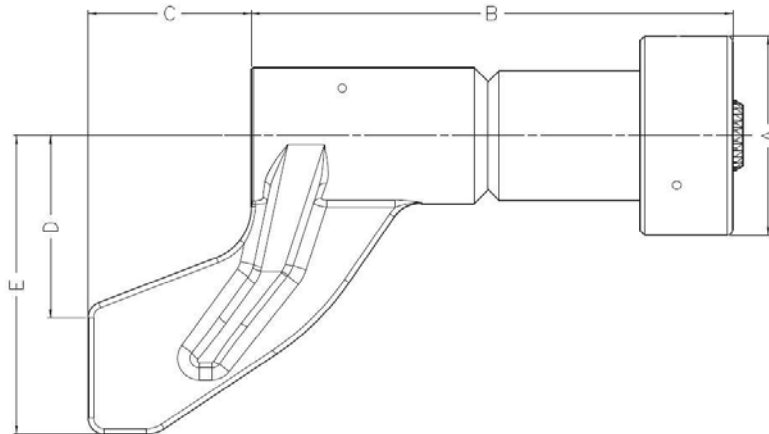

PART NUMBER	TO FIT	DIMENSIONS (mm)					WEIGHT (Kg)
		A	B	C	D	E	
18349.006	PT500-2000	73.2	177	60	67	110	3.1
18349.009		73.2	257	60	67	110	3.8
18349.012		73.2	330	60	67	110	4.3
18349.015		73.2	408	60	67	110	5.5
18349.018		73.2	477	60	67	110	6.1

PTM-52 (BLADED REACTION)

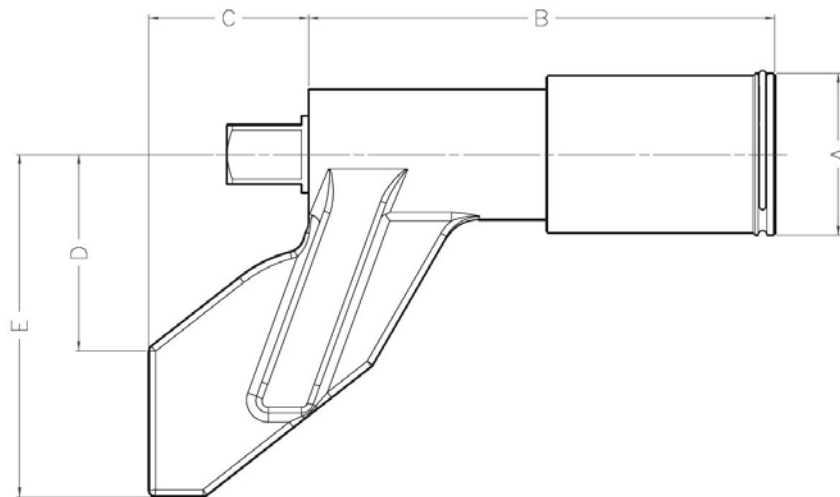

PART NUMBER	TO FIT	DIMENSIONS (mm)					WEIGHT (Kg)
		A	B	C	D	E	
18594.006	PTM-52	52	150	51	63	110	3.1
18594.009		52	228	51	63	110	3.5
18594.012		52	303	51	63	110	3.9
18601.006		52	150	51	63	110	3.1
18601.009		52	228	51	63	110	3.5
18601.012		52	303	51	63	110	3.9

PTM-72 (BLADED REACTION)

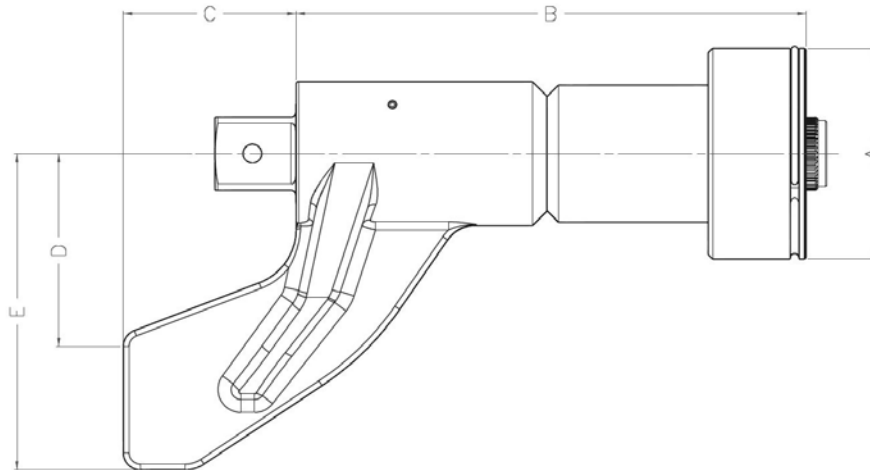

PART NUMBER	TO FIT	DIMENSIONS (mm)					WEIGHT (Kg)
		A	B	C	D	E	
18755.006	PTM-72	72	181	60	67	110	3
18755.009		72	257	60	67	110	4.1
18755.012		72	327	60	67	110	5
19007.006		72	181	60	67	110	3
19007.009		72	257	60	67	110	4.1
19007.012		72	327	60	67	110	5

PTM-52 / 72 / 92 (SPLINED REACTION)

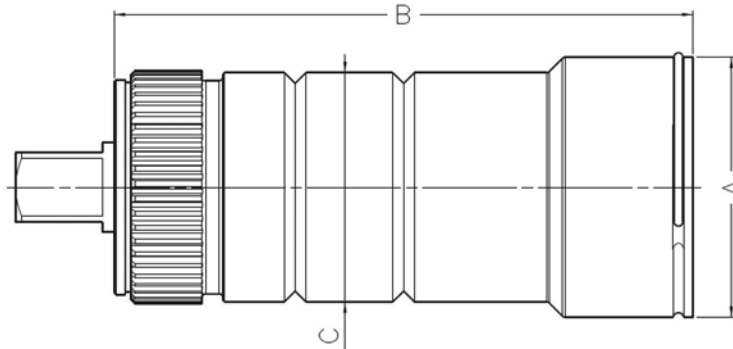

PART NUMBER	TO FIT	DIMENSIONS (mm)			WEIGHT (Kg)
		A	B	C	
19045.006	PTM-52	52	150	48	1.8
19045.009		52	226	48	2.4
19045.012		52	303	48	3.2
19046.006	PTM-72	72	160	63.5	2.9
19046.009		72	236	63.5	3.8
19046.012		72	313	63.5	4.8
19047.006	PTM-72/92	72	161	63.5	3
19047.009		72	237	63.5	4.2
19047.012		72	313	63.5	5.4

PTM-72 TRUKTORQUE NOSE EXTENSION

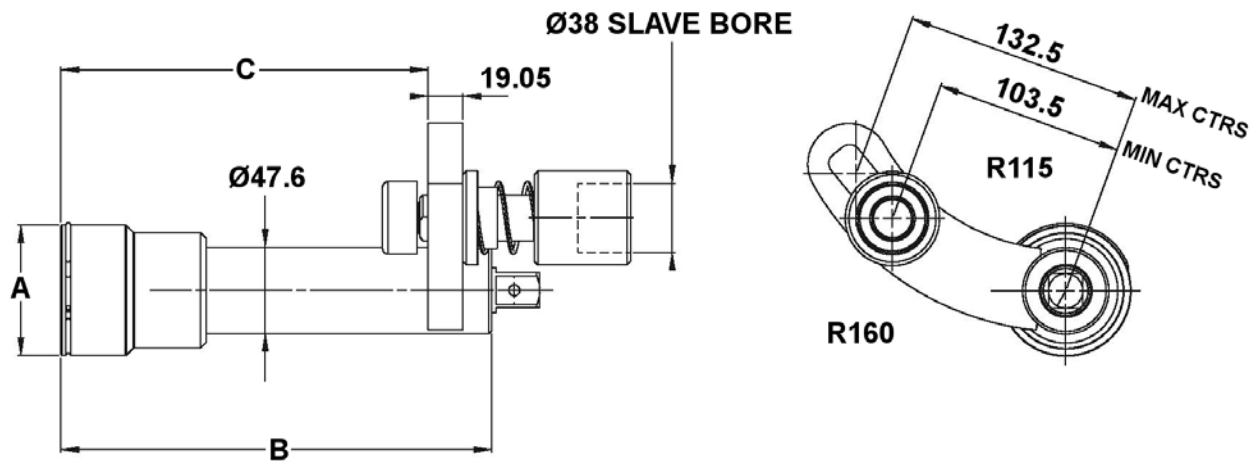

PART NUMBER	TO FIT	DIMENSIONS (mm)			WEIGHT (Kg)
		A	B	C	
19087.009	PTM-72	72	237.5	202.5	5.5
19087.012		72	314.5	279.5	6.3
19089.009	PTM-72	73.2	257	222	5.3
19089.012		73.2	326.7	297.1	6.2

FITTING INSTRUCTIONS

The various different fitting methods are listed for each nose extension below.

NOSE EXTENSION	FITTING METHOD
16480.***	A
16484.***	B
16542.***	C
16694.***	D
16695.***	E
18349.***	F
18594.***	G
18601.***	I
18755.***	H
19007.***	I
19045.***	I
19046.***	I
19047.***	I
19087.***	I
19089.***	I

A) 16480.***

- Remove 2BA bolts and take off reaction plate.
- Remove cover plate, bearing bush and bush from assembly. (See Figure 1)

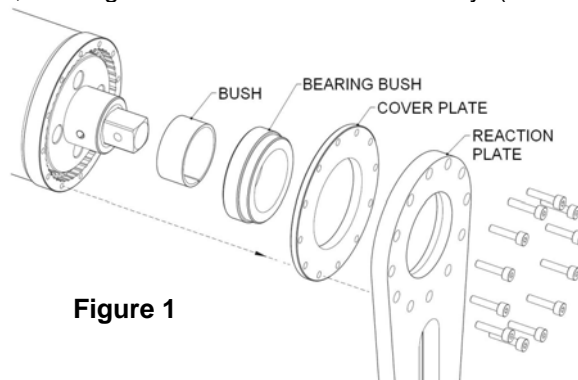

Figure 1

- Fit nose extension, rotate shaft to engage internal square, line up plate holes of nose extension with tool annulus holes.
- Fix with 2BA bolts; tighten to value of 9 N·m.

B) 16484 ***

- Remove ¼" BSF bolts and take off reaction plate.
- Remove bearing bush and bush from assembly. (See Figure 2)

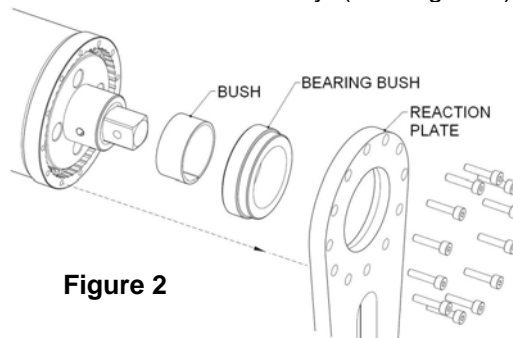

Figure 2

- Fit nose extension, rotate shaft to engage internal square, line up plate holes of nose extension with tool annulus holes.
- Fix with ¼" BSF bolts; tighten to value of 19 N·m.

C) 16542 ***

- Remove 2BA bolts and take off reaction plate.
- (PNEUTORQUE®) Remove cover plate, bearing bush and bush from assembly. (See Figure 1)
- (HANDTORQUE™) Remove bearing bush and bush from assembly. (See Figure 2)
- Fit nose extension, rotate shaft to engage internal square, line up plate holes of nose extension with tool annulus holes.
- Fix with 2BA bolts; tighten to value of 9 N·m.

D) 16694 ***

- Remove ¼" BSF bolts and take off reaction plate.
- Remove bearing bush and bush from assembly. (See Figure 2)
- Push out pin and remove square drive from carrier assembly. (See Figure 3)

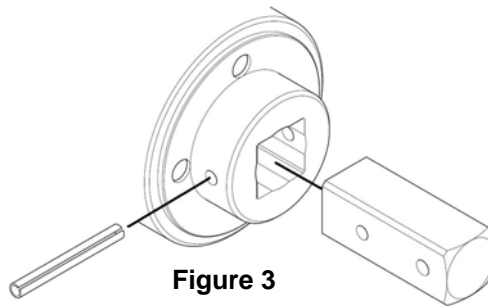
**Figure 3**

- Fit nose extension, rotate shaft to engage external square, line up plate holes of nose extension with tool annulus holes.
- Fix with ¼" BSF bolts; tighten to value of 19 N·m.

E) 16695 ***

- Remove 2BA bolts and take off reaction plate.
- Remove bearing bush and bush from assembly. (See Figure 2)
- Push out pin and remove square drive from carrier assembly. (See Figure 3)
- Fit nose extension, rotate shaft to engage external square, line up plate holes of nose extension with tool annulus holes.
- Fix with ¼" BSF bolts; tighten to value of 19 N·m.

F) 18349 ***

- Remove screw and take out drive square. (See Figure 4)

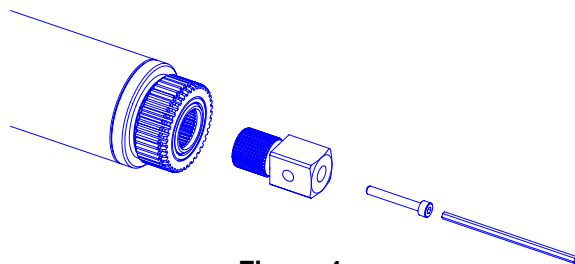
**Figure 4**

- Engage splines and rotate shaft until the internal splines engage. Push nose extension until it hits its stop.
- Secure nose extension to tool with 3 off M4 cup point screws. 5 - 10 N·m.
- Fit square drive to end of nose extension. Tighten M5 screw between 4 – 5 N·m.

G) 18594. *** _____

- Remove screw and take out drive square. (See Figure 4)
- Engage splines and rotate shaft until the internal square engage. Push nose extension until it hits its stop.
- Using a hammer and punch, tap in the two fixing pins.

H) 18755. *** _____

- Remove screw and take out drive square. (See Figure 4)
- Engage splines and rotate shaft until the internal spines engage. Push nose extension until it hits its stop.
- Using a hammer and punch, tap in the two fixing pins.

I) 18601.*, 19077.***, 19045.***, 19046.***, 19047.***, 19087.***, 19089.***** _____

- (Extensions with splined shafts only) Remove screw and take out drive square. (see Figure 4)
- Engage splines and rotate shaft until the internal spines/square engage. Push nose extension until it hits its stop.
- Push retaining clip into the groove making sure it is fully engaged. (see Figure 5)

**Figure 5**

These nose extensions have been designed to be retained to the PTM tool using a clip. PTM tools manufactured before September 2009 will require modification to the tool nose spline groove to allow any of these extensions to be securely fixed. PTM tools manufactured after September 2009 will have the correct nose spline groove as shown below. Please contact Norbar if the PTM tool does not match.

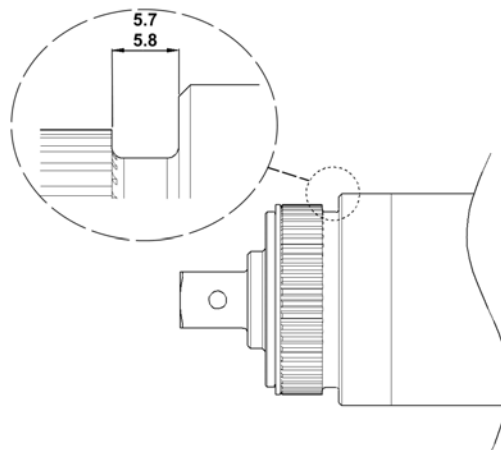

Diagram shows post September 2009 PTM tool with correct nose spline groove dimension.

OPERATING INSTRUCTIONS



WARNING: KEEP HANDS CLEAR OF THE REACTION BAR.



WARNING: WHEN USING THIS TOOL IT MUST BE SUPPORTED AT ALL TIMES IN ORDER TO PREVENT UNEXPECTED RELEASE IN THE EVENT OF FASTENER OR COMPONENT FAILURE.

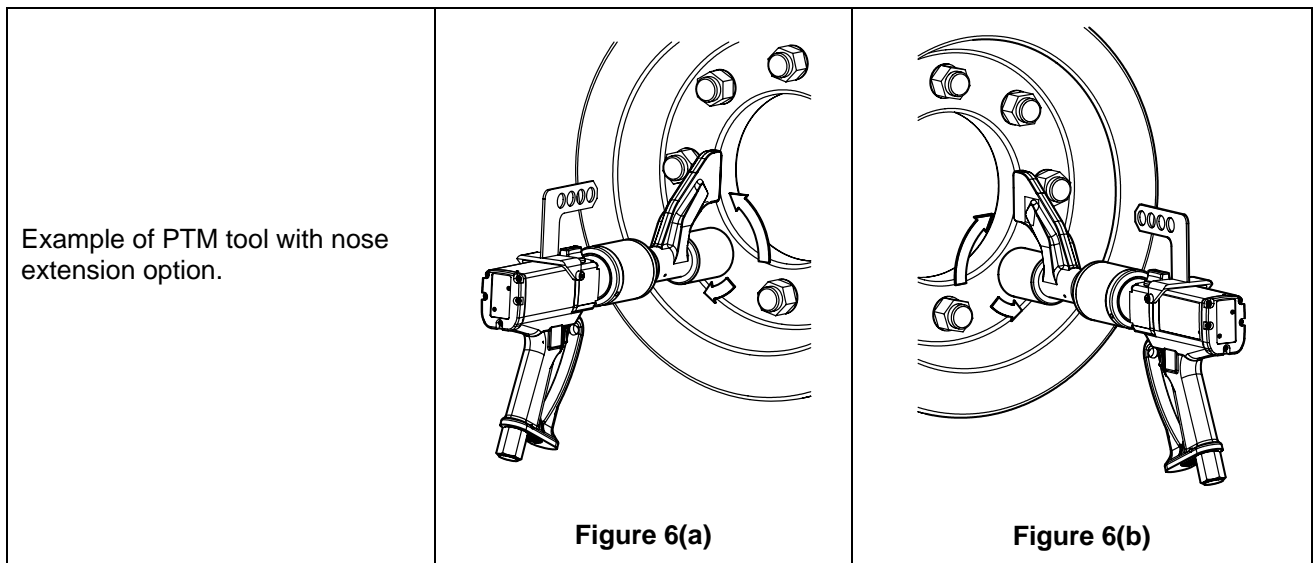

**REFER TO OPERATORS HANDBOOK FOR THE USE OF
PNEUTORQUE[®] / HANDTORQUE[™]**

MAINTENANCE

Drive Square/Shaft

To avoid internal damage (especially due to torque overload), the output drive square / shaft have been designed to shear first. This saves major internal damage and allows easy square removal.

In order to replace a broken drive shaft the nose extension needs to be removed.

- Remove nose extension from tool assembly.

If the drive shaft has failed.

- Remove the circlip using internal circlip pliers.
- Slide out shaft.
- Clean out housing to make sure there are no broken parts in the housing.
- Lightly grease the bearing bush.
- Slide in shaft.
- Replace circlip using internal circlip pliers.

Example:

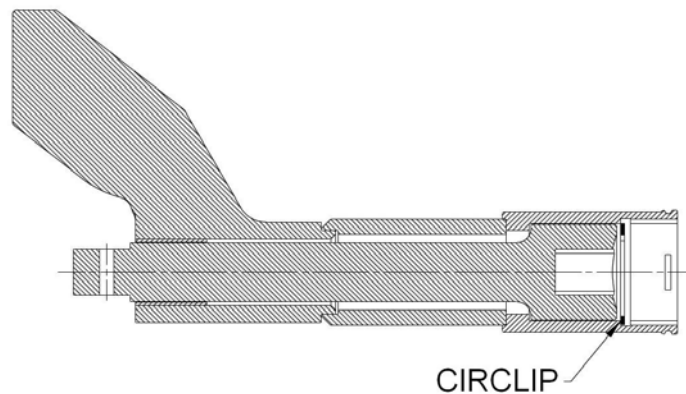

(Nose extensions 18755.* & 19007.*** only)**

In order to replace a broken drive shaft the shaft needs to be removed.

- Tap out the 1 slotted pin. (see Figure 7)
- Slide out the shaft.
- Lightly grease the Bearing bush.
- Slide in a new drive shaft.
- Tap in the slotted pin.

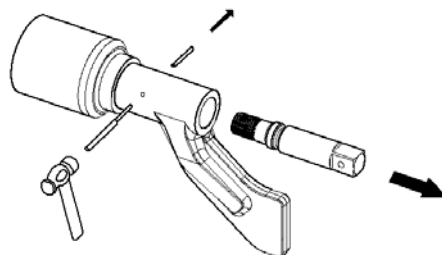
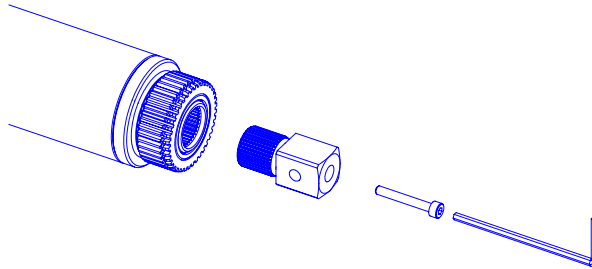

Figure 7

To replace square.

- Remove the screw then remove drive square.
- If the square has sheared it may be necessary to use pliers to remove the broken parts
- Fit new drive square.
- Fit new screw and tighten between 4 N·m and 5 N·m

**CLEANING:-** _____

Keep the tool in a clean condition to aid safety. Do not use abrasives or solvent based cleaners.

DISPOSAL:- _____**RECYCLING CONSIDERATIONS****Material:**

- Alloy steel with Epoxy finish.
- Alloy steel with chemical black finish / powder coat paint